

GasKraft
Engineering

CBH CARL
BAGUHN
HAMBURG



BoosterMeth – Methanol-Diesel- Emulsions Modul for Vessel Retrofits

Prof. Dr. Leander Marquardt, Benjamin Weisse,

Dr. Heiner-Joachim Katke, Gerold Vetter, Prof. Dr. Hinrich Mohr, Peter Seedorf, Sascha Spörl

Rostock-Warnemünde, November 21, 2025







Kofinanziert von der
Europäischen Union



Mecklenburg-Vorpommern

Agenda

-  Motivation and Project Approach
-  MDO-Methanol-Emulsion Concept and Module Development
-  Experimental Investigations at Hochschule Stralsund
-  Pilot Installation on Board M/V “Sandnes”
-  Conclusion & Outlook



Motivation: Global and Regulatory Context

Background:

- International shipping: 2–3 % of global CO₂ emissions (2020)
- CO₂ from fossil fuel combustion is one of the main contributors to global warming
- Reducing GHG emissions is therefore essential – alongside minimizing other pollutants and noise
- IMO GHG strategy (EEDI/EEXI, CII), FuelEU Maritime and EU ETS are tightening emission limits and raising cost pressure

Current Challenges:

- Increasing regulatory pressure to reduce GHG emissions
- Rising costs for the use of fossil fuels
- Energy-saving measures alone will not be sufficient to meet future requirements
- Alternative fuels are needed, but retrofit and fuel costs remain high
- Availability and future pricing of technically simple solutions (e.g. B100) are uncertain

© DNV 2023

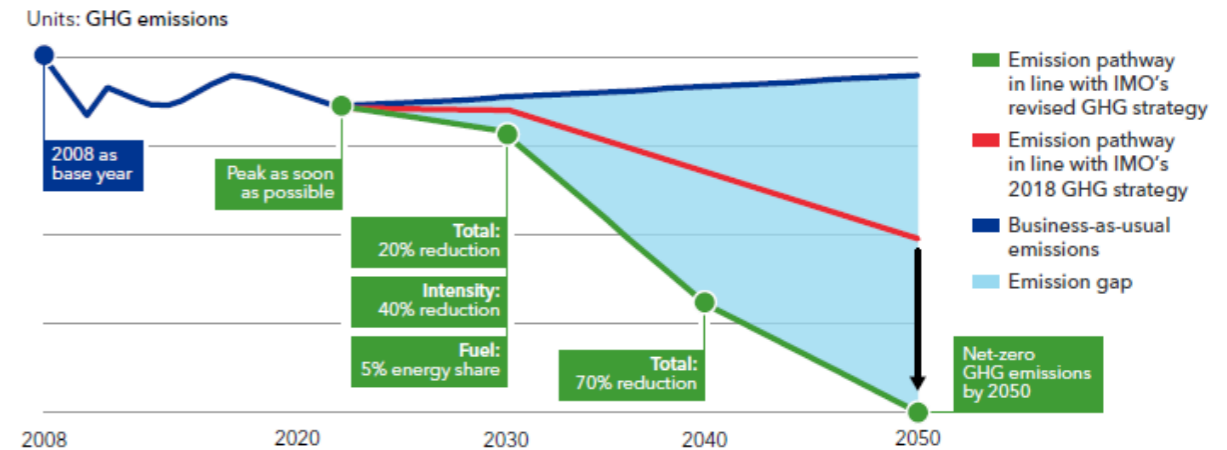

© DNV 2023

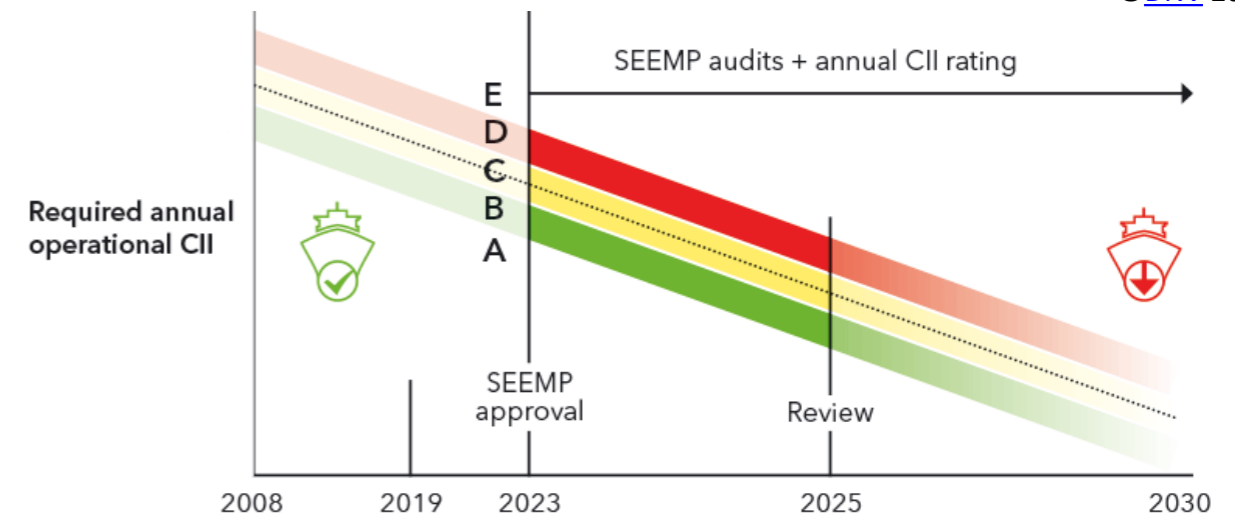

BoosterMeth Project Approach

Main Idea:

Development of a scalable, retrofittable and long-term reliable emulsion fuel module

→ enables blending of up to 30 mass % **green methanol** into MGO

→ creation of a stable and safe emulsion for onboard use

Technical & Practical Targets :

- Reduction of CO₂ and other emissions through substitution of fossil fuels
- Improvement of CII rating and reduction of operating costs
- No engine modification
- Simple integration into existing ship infrastructure
- Commercially feasible and technically uncomplicated retrofit
- Fast and easy installation as modular system
- Fuel flexibility: operation on diesel or emulsion
- Safe and reliable switching under all operating conditions



Target group:

Small and medium-sized ship owners/operators aiming to cut emissions and extend vessel lifetime



BoosterMeth Project Consortium



Project Partners

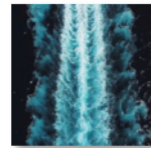

**GasKraft
Engineering**

Expertise Support



**Associated Partner
Installation Support**



**Associated Shipowner
Partners**

Concept of the BoosterMeth Module

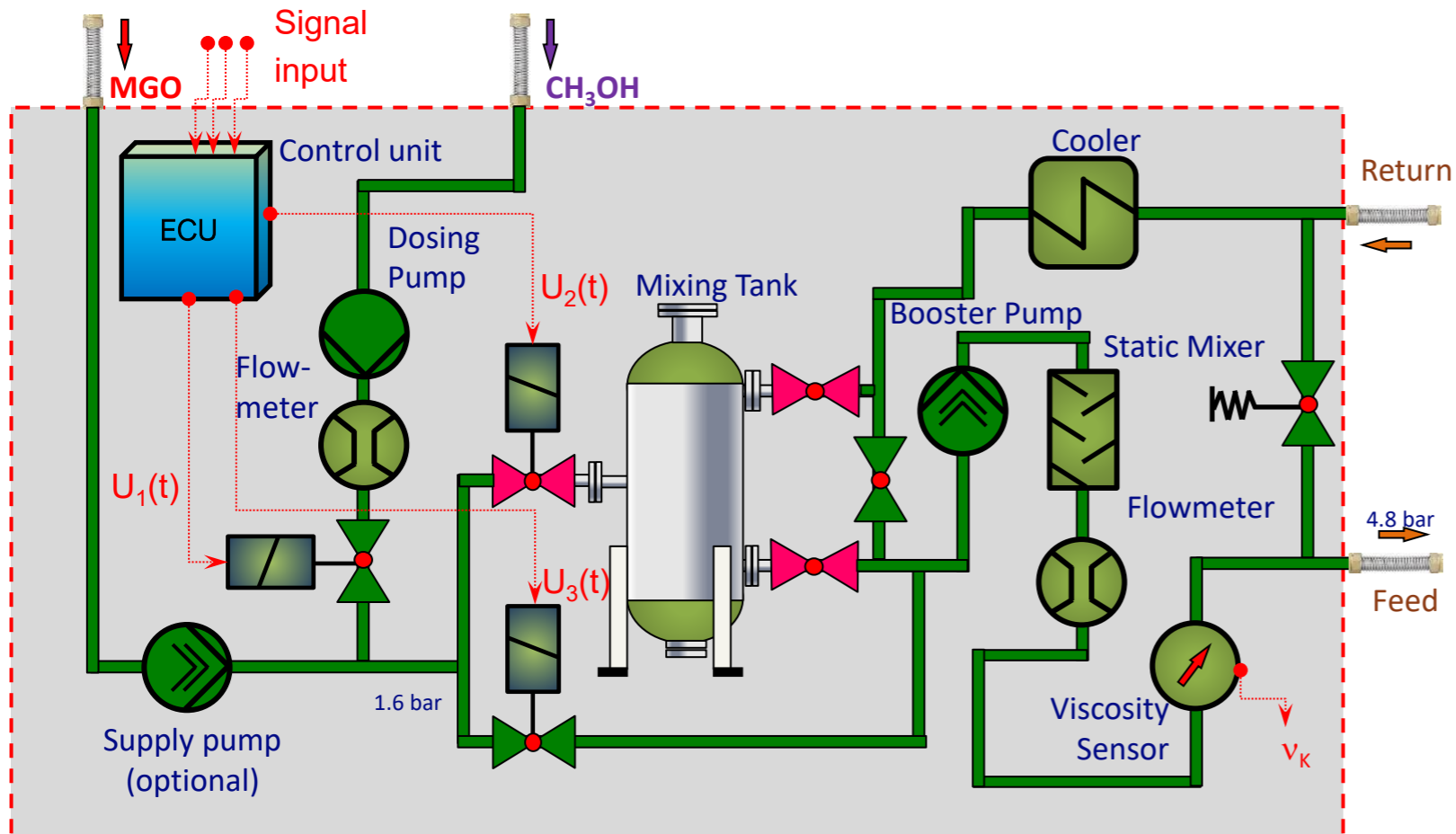

- Integration of the emulsion fuel module upstream of the existing booster unit
- Automated admixture of up to 30 % methanol into MGO
- Stable MDO–methanol emulsion generation under all operational conditions
- Safe and controlled change-over between diesel and emulsion operation
- Designed as a compact retrofit system, easy to install and integrate



Not all mixing is the same



Challenges:

- Consideration of Methanol characteristics: low flash point, high toxicity, ultra-low viscosity
- Material selection: resistant components and gaskets
- Accurate viscosity & density measurement for process control
- Reliable emulsion stability under all operational conditions – precise mixing and trustworthy monitoring
- Integration into existing fuel system with minimal intervention
- Impact on engine behavior and emissions

Module Engineering & Testing:

- Pre-testing with a safe medium at manufacturer's site
- Intuitive control system for safe and easy operation
- Classification society supervision during design and test stages

Reliable and class-compliant engineering and production of modules



Single-cylinder research engine FM16/24:

- Medium-speed Diesel-engine (up to IFO380)
- $V_h = 4.825$ litres , $\epsilon_c = 15.6$, $p_{Zmax} = 170$ bar
- Conventional injection, $p_{Emax} = 1020$ bar
- $P_{eZ} (9L) = 101$ kW/cyl. @ 1200 rpm

Testbed equipment and engine control room:

- Exhaust-gas analyzer HORIBA MexaOne (NDIR, CLA, FIA, MPA)
- FIA Testa 2010T for safety-equipment



FM16/24 „Norbert“

- Control for cooling-tower
- Web-cam for testbed
- Monitor for engine control
- Remote Panel BoosterMeth Module
- Control board for test-bed

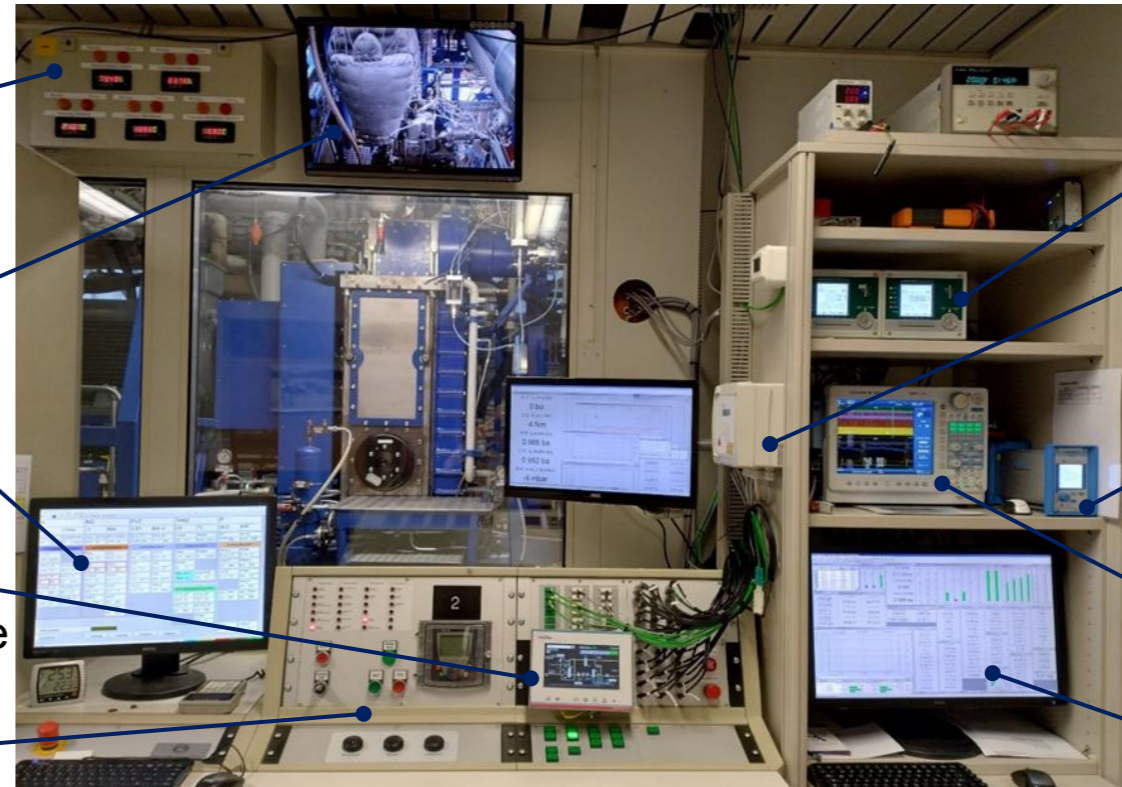

- 2 x Data logger
- Gas monitoring
- Charge amplifier
- Indicator system
- Data aquisition

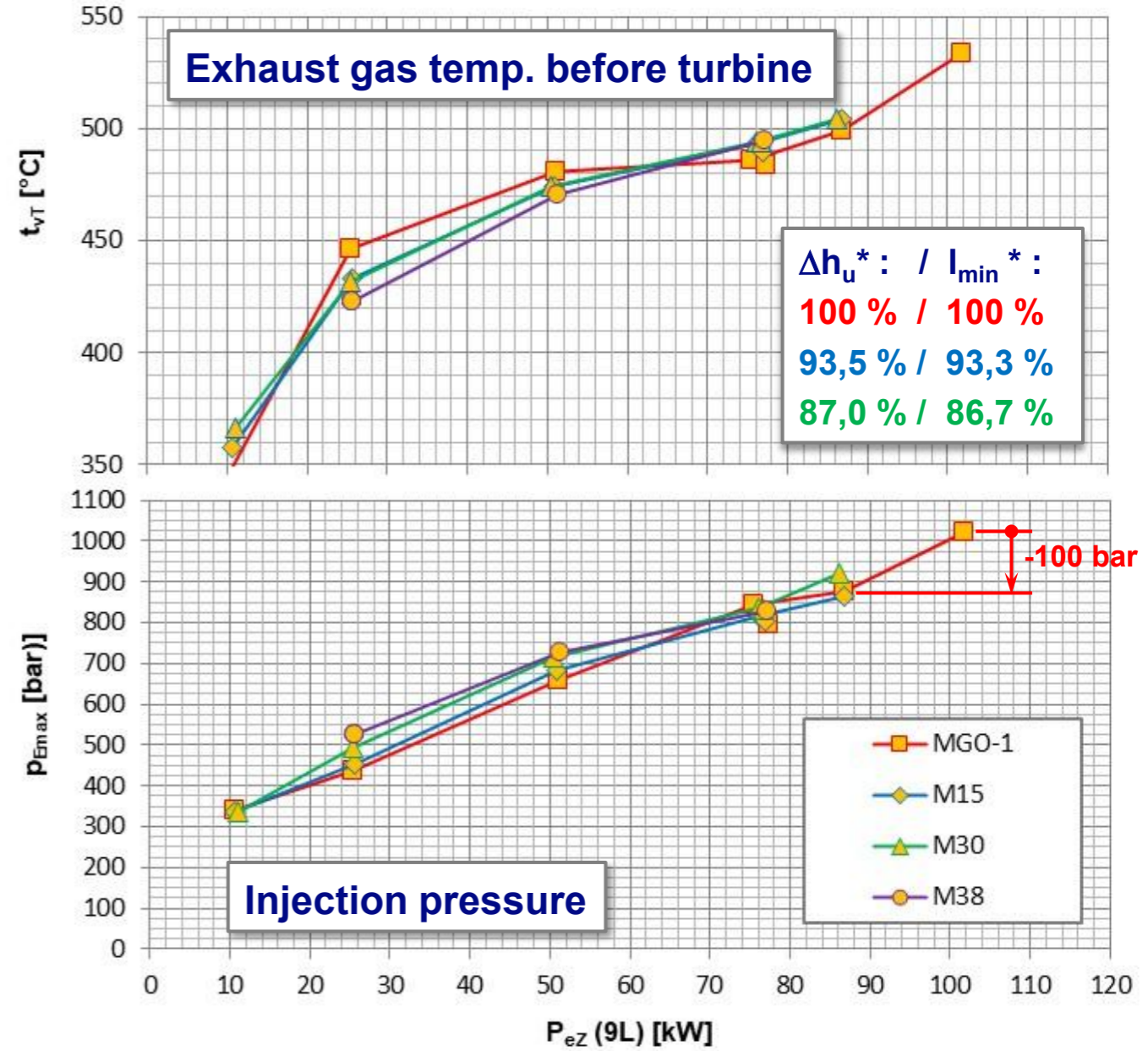
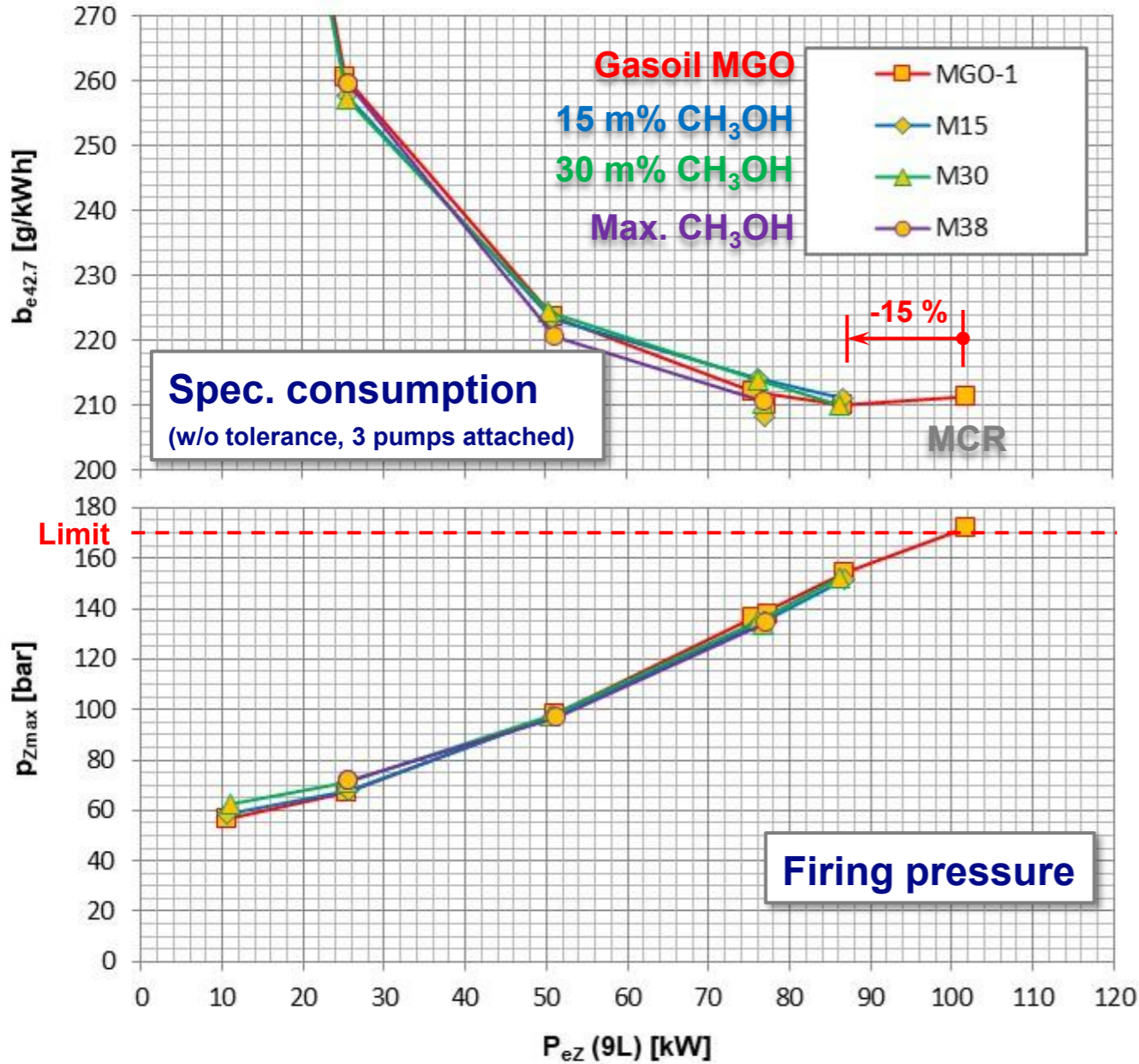

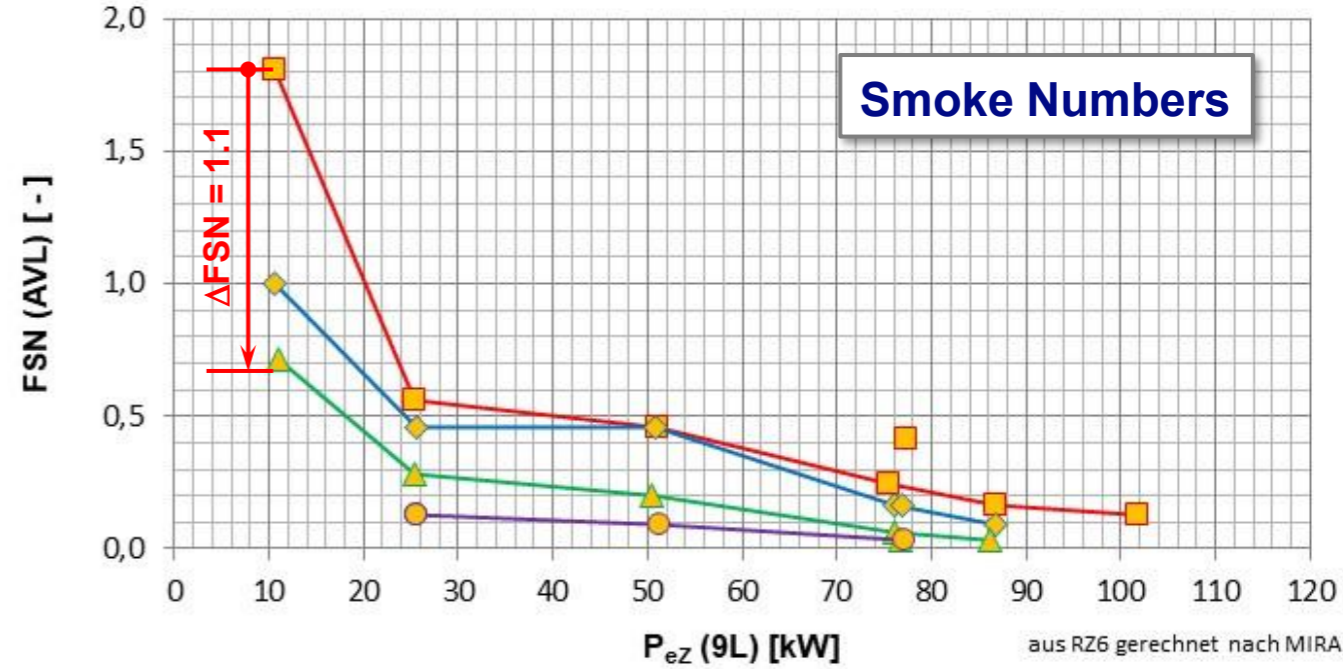
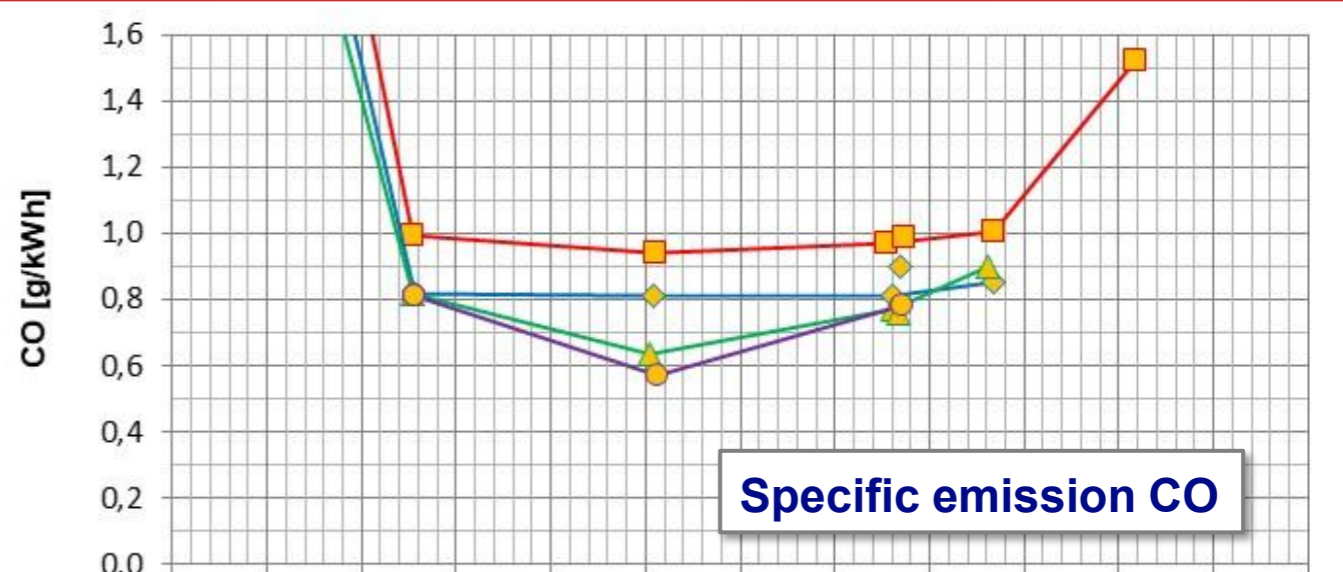
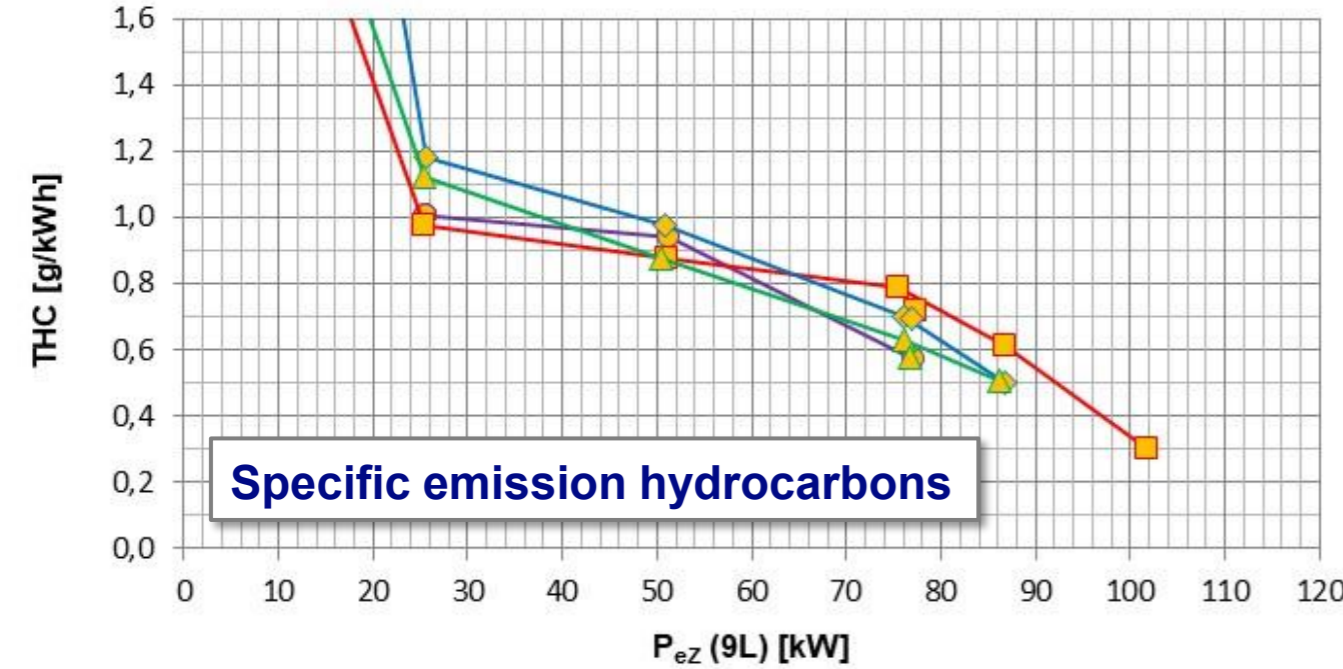
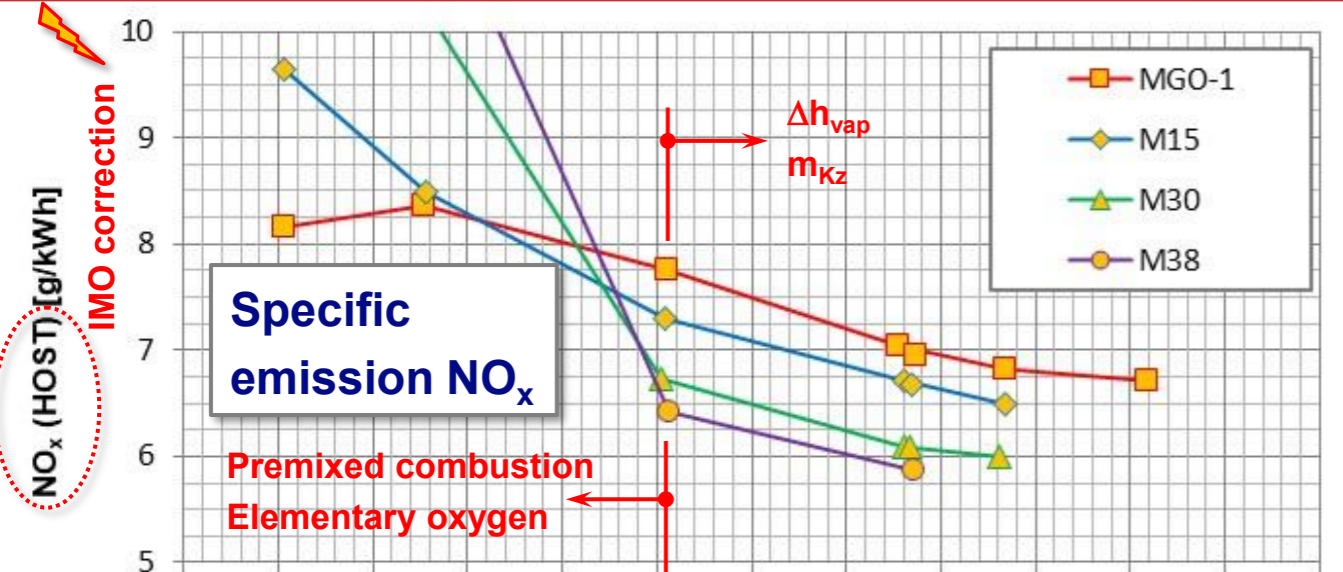

aus RZ6 gerechnet nach MIRA

HC-content inside crankcase:

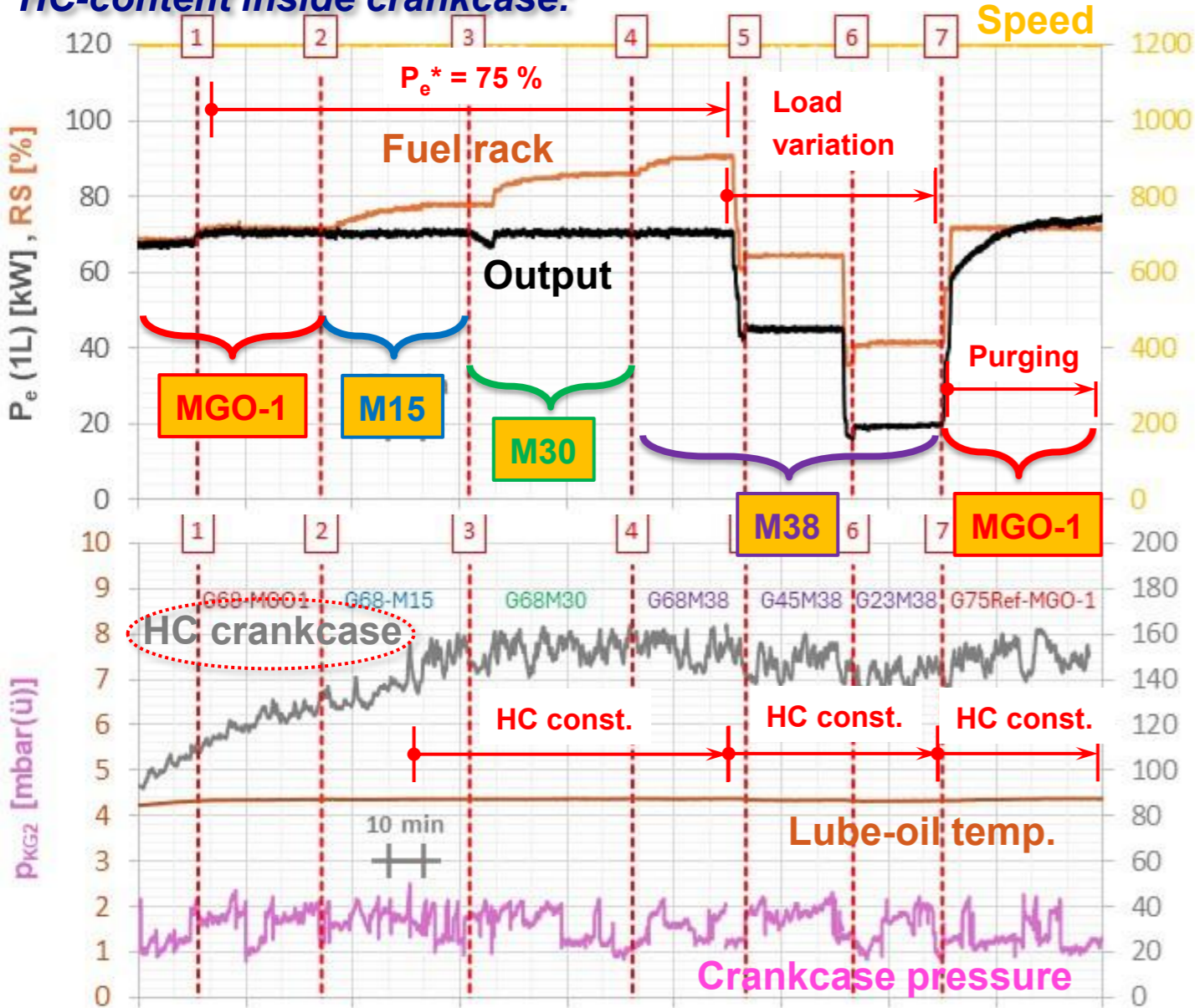

Dilution and contamination of lubrication-oil:

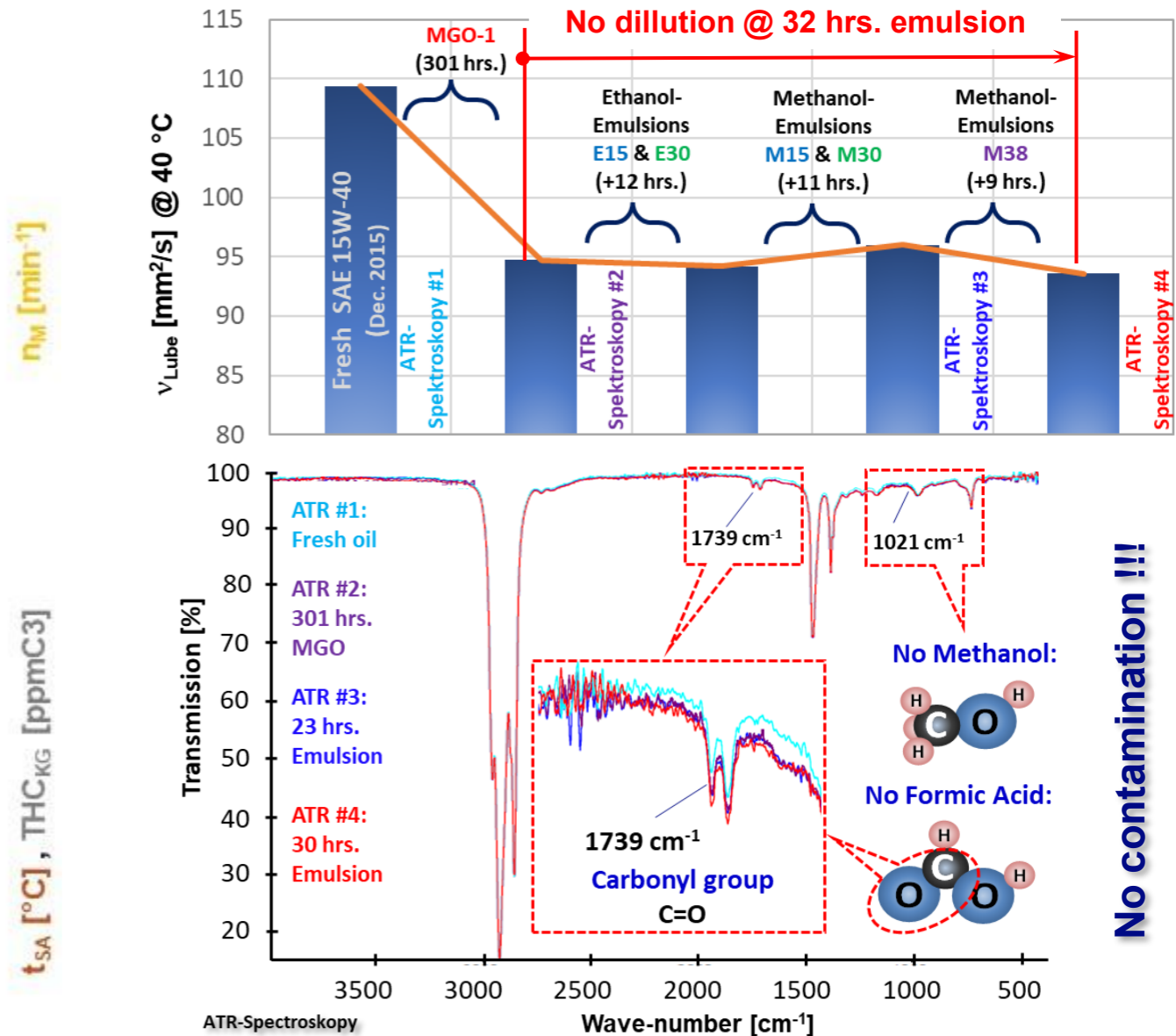

No problems with cylinder components:

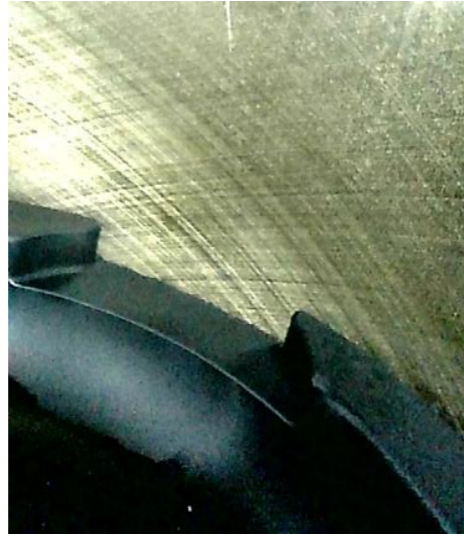

Cleaning effect of methanol-rich fuels at liner and piston witnessed

No problems in tribology observed

Problems with common elastomeres in dual-use:

Methanol-resistant emergency shut-off valves:

Original 4 hrs. MGO



Methanol-resistant pulsation dampers:

12 hrs. MGO



Search for reliable elastomer in operation with MGO/Methanol-blend

Engine operation:

- Stable and safe engine operation up to **M30**
- Small pmi-deviations at low load will allow synchronising
- No load-dependend methanol-share possible
- Massive cylinder pressure gradients @ **M38**

Emissions:

- NO_x, CO, HC, FSN decreasing @ P_e ≥ 50 %
- Enlarged NO_x emission @ P_e < 50 %
- ΔCO₂ ≈ -20 % (well-to-wake @ constant output)

Tribology / corrosion / material resistance:

- No dilution or contamination of lube-oil
- No toxic crankcase atmosphere
- Problems with common elastomers

→ **Functional prototype**



Further information:

MTZ 11/2025

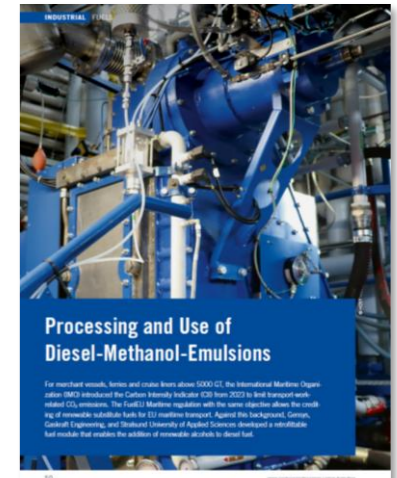

We are looking forward to your response.

Pilot Installation on Board M/V Sandnes

Objective:

- Validation of equipment under real conditions on CAT 3508B auxiliary engine (4-stroke)
- Inspection of all engine parts after specified running hours
- Temporarily installation of methanol tank
- Verification of functionality, safety, and operability

Safety & Compliance:

- Approval in Principle (AiP) process ongoing with DNV → based on MSC.1/Circ.1621 and IGF Code
- A60 gas-tight enclosure with ventilation, vapor detection, fire extinguishing
- ATEX Zone 1 components; control cabinet outside hazardous area
- Automatic fallback to diesel mode in case of alarm



Aux. Engine CAT 3508B

Bulk carrier	
	
M/V Sandnes	
DWT	27.711
GT	17.357
Main Power	7.300 kW after EPL 3.955 kW
Aux. Power	3x 682 kW
Speed	14 kn
Other	1 Boiler

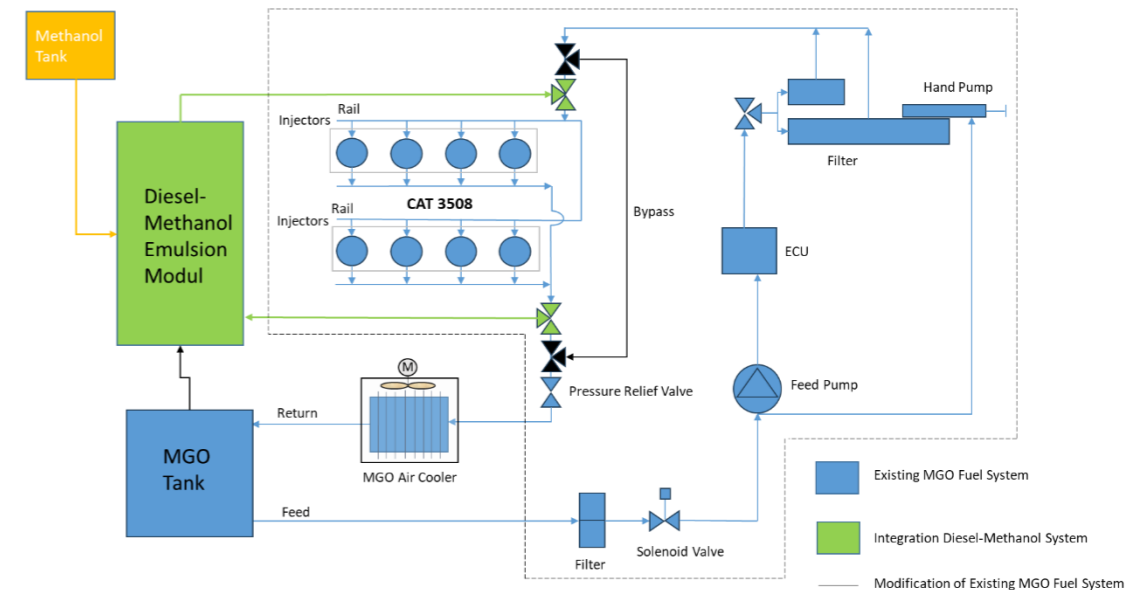

Conclusion & Outlook

Conclusions:

- **Green methanol** shows high potential as alternative marine fuel to reduce CO₂ emissions
- Methanol–diesel blending up to 30 vol-% proved technically feasible
→ no negative engine effects, no recertification required
- Special attention required for elastomer and gasket materials
- BoosterMeth module offers a cost-efficient retrofit solution for existing ships
→ requires only methanol tank, blending unit, and minor modifications

Project Achievements:

- Successful testing on single-cylinder high-speed and medium-speed engines
→ proof of concept and validated emulsion stability
- Module design completed and ready for onboard integration
- Two shipowners already joined as pilot partners

Outlook:

Next step: Approval in Principle (DNV) and Field trial on M/V Sandnes (2026)
→ real-life validation under operational conditions





Thank you for your interest!

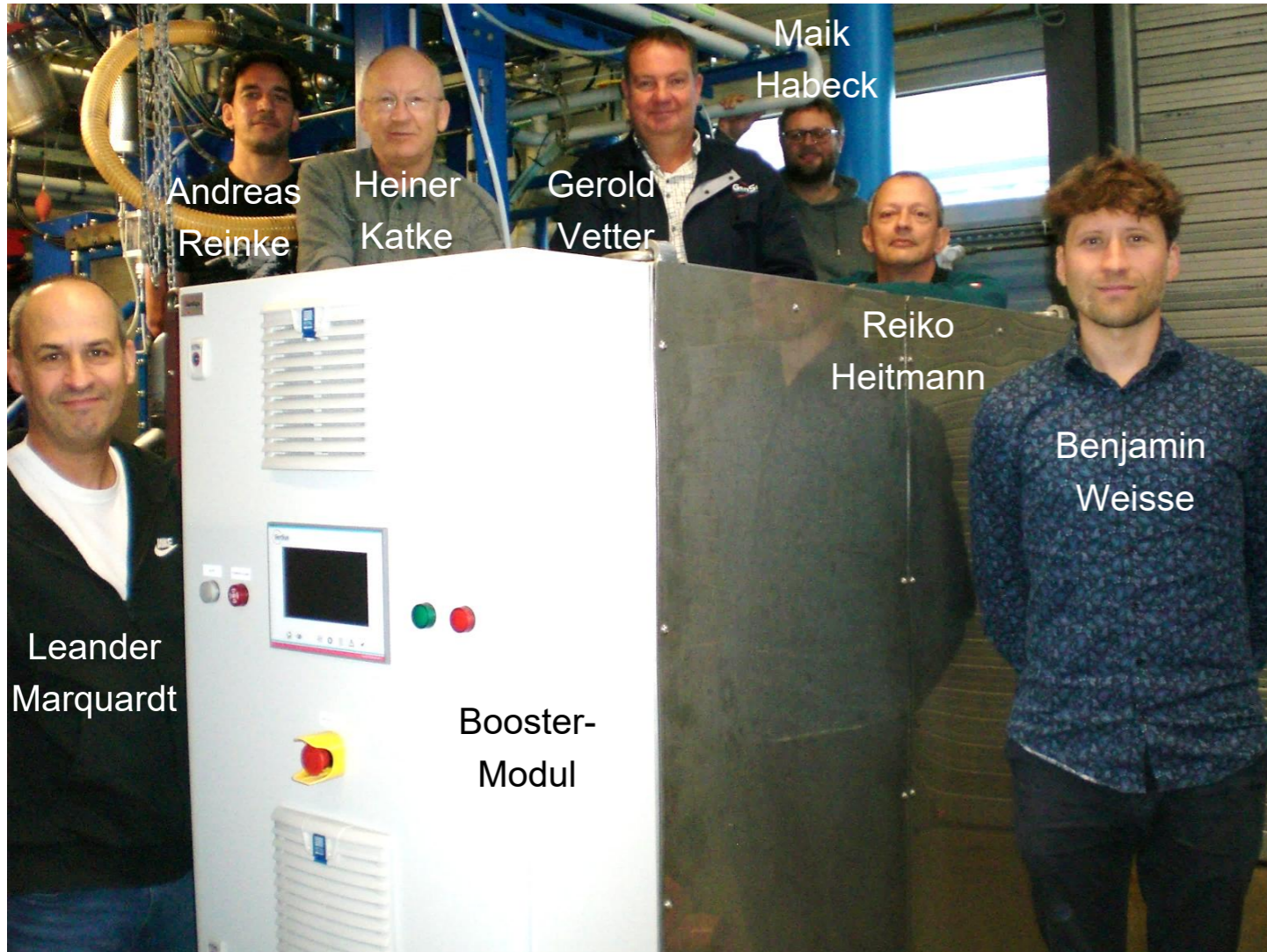

Leander Marquardt

Andreas Reinke

Heiner Katke

Gerold Vetter

Maik Habeck

Reiko Heitmann

Benjamin Weisse

Booster-Modul

Support:



- GHS13-0026 „Totgewichtswaage“ (IRES)
- GHS16-0027 „Messkette Rest-O2“
- GHS16-0028 „ScopeCorder“
- GHS16-0033 „Messsystem Druckschwingungen“
- GHS17-0024 „Ladungswechseoptimierung“



- Landesförderung MV
- TBI-1-011-W-004)
- TBI-1-010-U-004



ATR-Schmierölanalysen



- INST 295/44-1 FUGG „Einzylinder“
- INST 295/54-1 „Abgasanalyse“

Contact:

Prof. Dr.-Ing. Leander Marquardt
 Kolbenmaschinen & Thermodynamik
 Fernsprecher: +49 3831 456545
leander.marquardt@hochschule-stralsund.de
 Zur Schwedenschanze 15 • 18435 Stralsund • Haus 19/Raum 317
 Fakultät für Maschinenbau

M.Eng. Benjamin Weisse
 Senior Development & Project Engineer

GenSys GmbH
 Zum Dock 3 - 23966 Wismar - Germany
 Telephone: +49 (0)3841 - 7125-15
 Telefax: +49 (0)3841 - 7125-23
 www.gensysgroup.com bweisse@gensysgroup.com